

ONKYO® SERVICE MANUAL**DIRECT DRIVE FULLY
AUTOMATIC TURNTABLE
MODEL CP-1027F****TABLE OF CONTENTS**

Item	Page
Specifications	2
Circuit Description	2
Adjustment procedures	4
Component location	5
Printed circuit board view from component side	7
PC board-parts list	7
Schematic diagram	9
Service guide	11
Packing procedures	12

**ONKYO®
AUDIO COMPONENTS**

ADJUSTMENT PROCEDURES

1. Lead-in Adjustment

Roughly adjust the pulley shutter so the stylus lowers approximately into the lead-in grooves of a record. Next, adjust the jumper circuit (J220 – J225) on the printed circuit board (NADG-1046).

Press the record size selector to 30cm position and confirm the lead-in position. When outside the lead-in position, connect or cut the jumper wires by referring to the below table.

	Cut	Connect
J225	inner	outside
J220	0.3 mm	
J221	0.6 mm	
J222	1.2 mm	
J223	2.4 mm	
J224	4.8 mm	

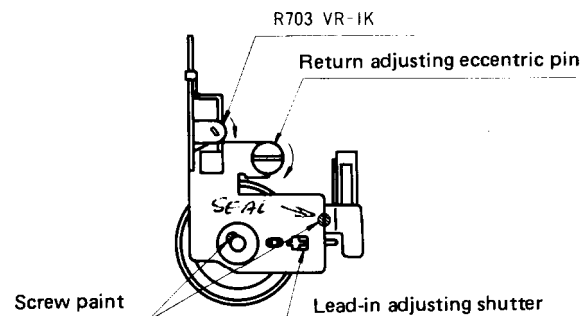

2. Auto-Return Adjustment

2-1. Sensitivity Adjustment

*Remove the DD motor and arm motor connectors and connect a millivoltmeter between the GND and "IN" of the terminal of DG-AS (NADG-1046).

*Move the tonearm to the innermost part of the record and, in a position such that the pulley and deflection pin do not cover the end sensor (D701, D702), turn R703 counterclockwise as far as it will go and read the value on the millivoltmeter. (should be about 100mV)

*Next, turn R703 clockwise to the point where the millivoltmeter value has changed 2 – 3mV and set R703 at that point.

Notes: 1. Do not cover the light of the outdoor during adjustments.

2. If parts on the printed circuit board of RET-AS are replaced, perform the sensitivity adjustment procedure described above. No adjustments are necessary when other parts are replaced.

2-2. Auto-return position

Adjust the return position by the eccentric pin attached by the tonearm base. To adjust the return position for faster, turn the eccentric pin clockwise. To adjust the return position for later, turn the eccentric pin counter-clockwise.

3. Tonearm Height Adjustment

Turn the adjustment screw on top of the elevation section clockwise to lower and counterclockwise to raise the height of the tonearm during fully automatic operations.

specification 13 ~ 15mm

4. Speed Adjustment

Set the speed control VR of the operation section to about its mechanical center and, after confirming that the green LED in the speed indicator window is illuminated, adjust VR-45 and VR-33 on the main motor so that a 3kHz test record is 3,000Hz at 45 rpm and 3,000Hz at 33 rpm.

COMPONENT LOCATION

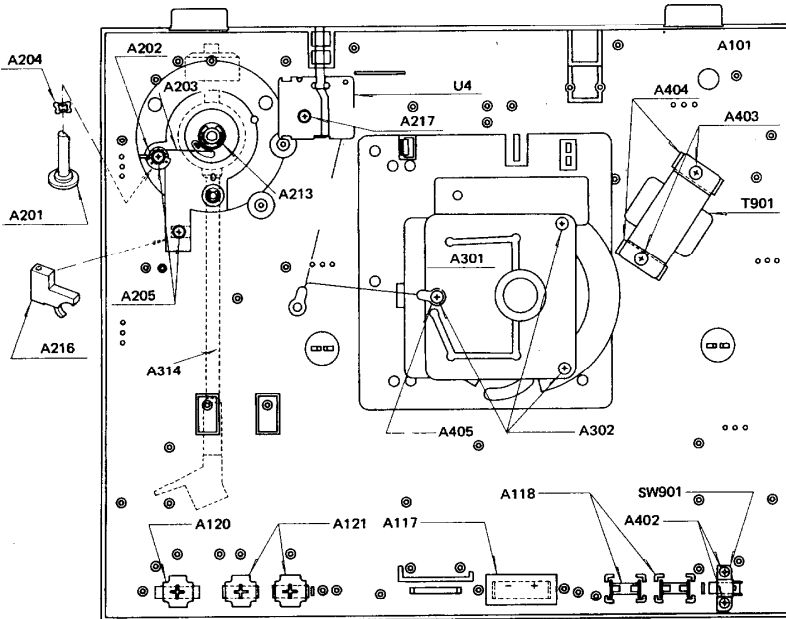
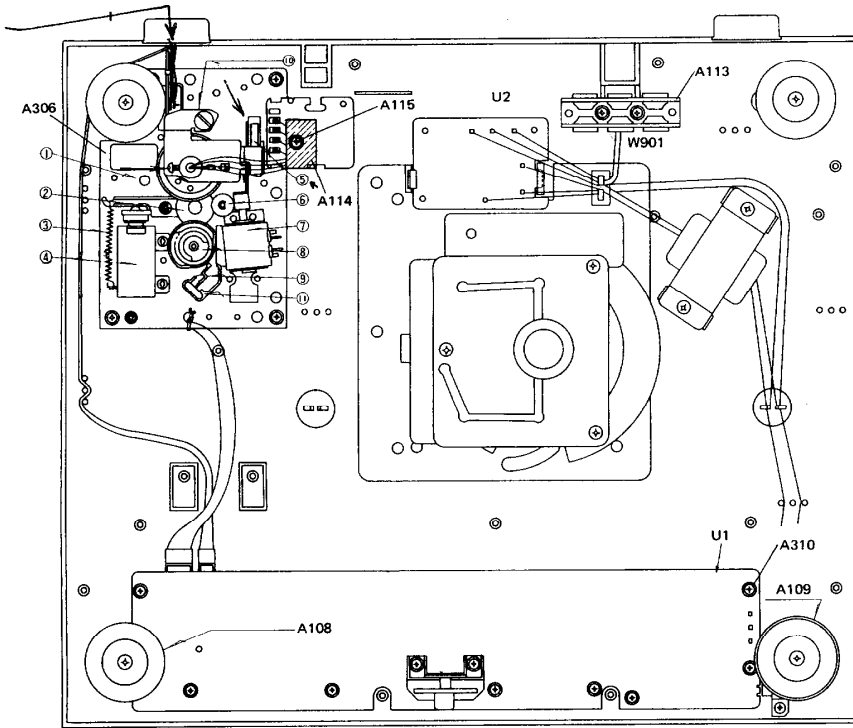

PARTS LIST

SYMBOL NO.	PARTS NO.	DESCRIPTION
A101	28110210	Cabinet ass'y
A103	27262086	Plate, switch
A104	27170086Z	Bottom board
A105	831130100	3TTW+10P, Tapping screw for bottom board
A106	24509215	Dust cover ass'y
A107	28180062	Hinge
A108	24509232	Insulator
A109	27270058	Spacer
A110	833140120	4TTP+12P, Tapping screw
A111	833140200	4TTP+20P, Tapping screw
A112	27140449	Bracket, volume
A113	28400010	Holder, power supply cord
A114	27150133	Shielded plate
A115	831130100	3TTW+10P, Tapping screw
A117	28191070	Clear plate
A118	28320446	Knob S
A119	28320489	Knob M, Power
A120	28320517	Knob LT
A121	28320518	Knob MT
A201	28320490	Knob, IFC
A202	28400012A	Cam, IFC
A203	27180071	Spring, IFC
A204	870071	Wave washer
A205	831130100	3TTW+10P, Tapping screw
A208	24501363	Lifter plate
A209	27260054	Lifter shaft
A210	24506533	Screw
A211	27180067	Spring
A212	27180068	Spring
A213	8930305	Circlip
A216	28400013	Tonearm rest
A301	24502123	Motor
A302	833140120	4TTP+12P, Tapping screw
A304	24502120	Turntable platter
A306	24506534	Fulley automatic mechanism ass'y
1		Mechanism ass'y
2	24504310	Lever
3	24503100	Spring
4	24506474	Solenoid
5	24503108	Microswitch
6	24503097	Wheel
7	24502125	Motor
8	24503098	Cam wheel
9	24503102	Leafswitch
10	24506536	Pulley ass'y
11	24506463	Cover
A307	27140411	Bracket L
A308	834130082	3STS+8BQ, Tapping screw
A310	831130100	3TTW+10P, Tapping screw
A314	24501383	Tonearm ass'y
	24501321A	Screw, headshell
	24501385	Counter weight
	24501354	Headshell
	24501330	Cartridge mounting part ass'y (D)
	24501346	OC-51M, Cartridge (G/Q/U)
	24501308	DN-51ST, Stylus (G/Q/U)
	24501283	Stylus cover (G/Q/U)
	24501287	Screw (G/Q/U)
	24501123	Nut (G/Q/U)
	24500079	Washer (G/Q/U)
	28140340	Cushion
A318	870073	W10x18x1, Washer
A319	890010	E-8, Circlip
A320	831130100	3TTW+10P, Tapping screw
A401	833130100	3TTP+10P, Tapping screw
A402	833140120	4TTP+12P, Tapping screw (D)
A403	833140200	4TTP+20P, Tapping screw (G/Q/U)
A404	270520	Support (D)
	27265035	Ring (G/Q/U)
	87614012	W4x12F Washer (G/Q/U)
A405	251073	Terminal
D701, D702	225049 or 225050	SEL1121R (B) or SEL1121R (C), L.E.D.
SW901	25035267	NPS-111-L231P, Power switch
T901	230518	NPT-735D, Power transformer (D)
	230515	NPT-746G, Power transformer (D)
	230522	NPT-746AG, Power transformer (G)
	230527	NPT-746Q, Power transformer (Q)
U1	16644546A	NADG-1046a, Digital and power supply pc board ass'y (D/G/Q)
U1	16640546B	NADG-1046b, Digital and power supply pc board ass'y (J)
U2	16639547A	NAPS-1047a, Power supply pc board ass'y (D)
	16644547B	NAPS-1047b, Power supply pc board ass'y (D)
	16640547C	NAPS-1047c, Power supply pc board ass'y (G)
	16640547D	NAPS-1047d, Power supply pc board ass'y (U)
	16643510D	NAPS-1047d, Power supply pc board ass'y (Q)
U3	16626517A	NARET-917a, Return circuit pc board ass'y
U4	16627510	NAPI-1010, Output terminal pc board
W901	253099A	AS-UC-3, Power supply cable (D)
	253083	AS-CEE, Power supply cable (G/U)
	253077	Power supply cable (Q)

Note:
(D): Only 120V model
(G): Only 220V model
(Q): Only 240V model
(U): Only universal model

SCHEMATIC DIAGRAM

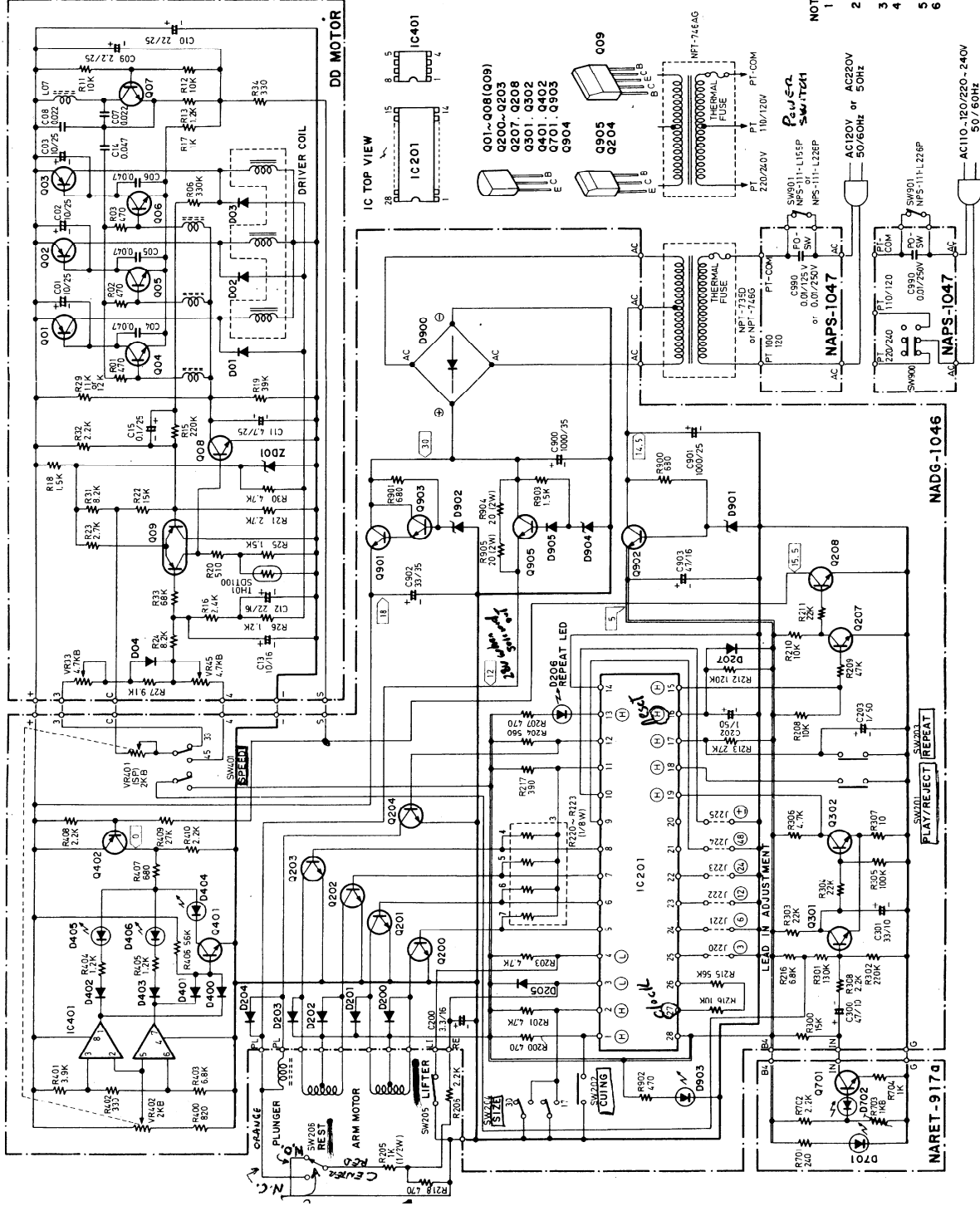

- IC201 TMP4310AP (4411)
- IC401 NJM4558D
- 001-003 2SA952 2SB951 2SA509
- 004-008 2SB905 2SC2330 2SC372
- 009 2SC456 LC945 2SC536
- 0200-0203 2SC828 JAI350 2SC1815
- 0204 2SC733 2SC2031
- 0207 2SA736 2SA733 2 2SA998 2
- 0208 2SA608 2 2SA640 2 L733 2
- 0209 2SA933 2 2SA1015 2 2SA564 2
- 0210 2SC1953
- 0211 2SD985
- 0301 0302 2SC1815 2SC945
- 0401 0402 2SD471 (2SD0880)-UU
- 0901 0902 2SD080
- 0901 0902 2SA1015

- D01-003 1S953
- D04 R05.1E H25C
- D200-D205 DS442X IS1555
- D400-D403 SEL112IR
- D406-D408 SEL132IG
- D404 W01
- D900 GZAS 6U
- D901 GZAI8U
- D902 GZAI5L
- D904 SEL110R
- D701 SP29S SP254S
- D702

- Q01-Q09 Q901-Q902
- Q200-Q203 Q405 2SD820
- Q301-Q302
- Q204

- D206-D405
- D404-D406
- D903
- D701
- D702

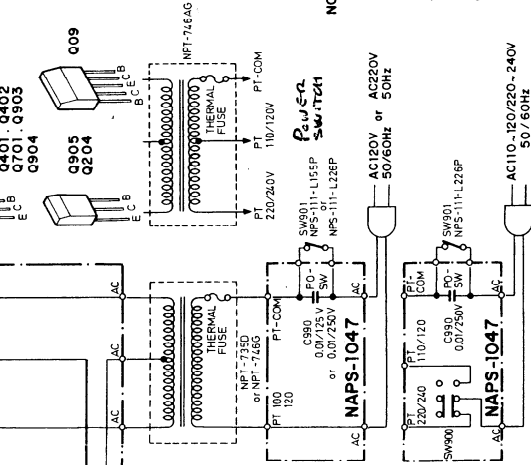

- NOTE
- 1. ALL RESISTORS ARE IN OHMS, 1/4WATT UNLESS OTHERWISE NOTED.
- 2. ALL CAPACITORS ARE IN JF, 50VW UNLESS OTHERWISE NOTED.
- 3. ELECTROLYTIC CAPACITORS (±H-) ARE IN JF/WV.
- 4. VOLTAGE IS MEASURED WITH V.T.V.M. WHEN TONEARM IS IN REST POSITION.
- 5. Ⓚ SYMBOLS SHOW WITH THE POSITIVE LOGIC.
- 6. CIRCUIT IS SUBJECT TO CHANGE FOR IMPROVEMENT.

SERVICE GUIDE

1. Attaching the cartridge

Attach the cartridge as shown below, connecting each of the color coded lead wires to the proper terminal. If a mistake is made, no sound will be heard or stereo reproduction will be lost. Also, to prevent damage to the stylus during installation operations, leave its cover on or remove the stylus completely.

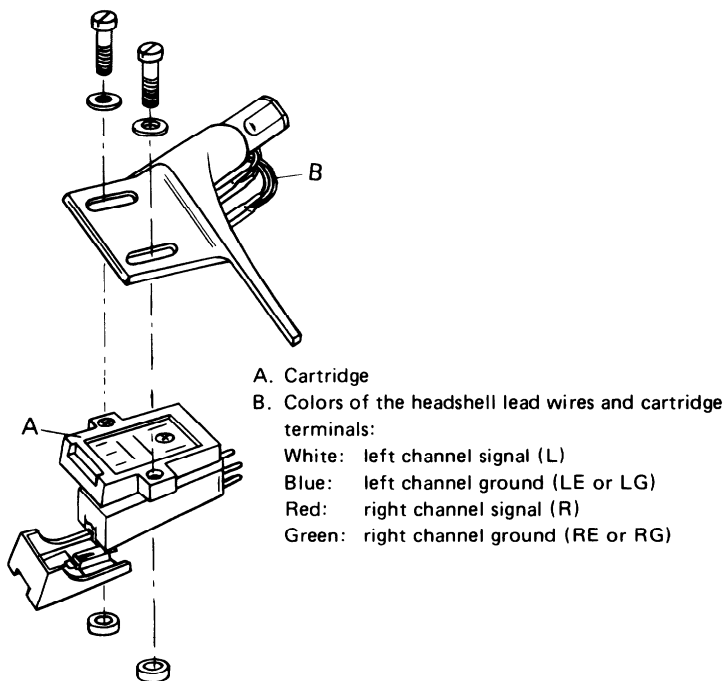

Adjust so the distance between the stylus tip and the base of the headshell is 30 mm (1 3/16") and tighten the screws. This assures the effective length and overhang of the tonearm are correct.

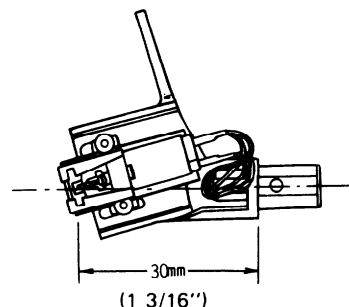

Use the included overhang gauge as shown below, placing the cartridge in the gauge and setting the location of the stylus tip as indicated.

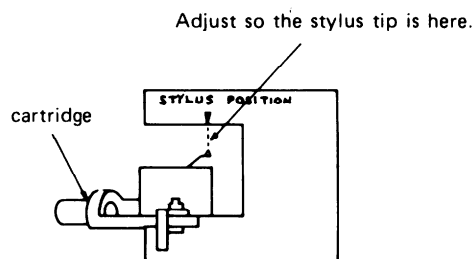

After attaching a different cartridge, always balance the tonearm again and set the appropriate tracking force.

2. Voltage selector (Universal model)

The voltage selector is located on bottom of the cabinet. If a voltage change is necessary, change the voltage selector switch to the proper voltage.

110 - 120 V ~

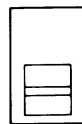

220 - 240 V ~

PACKING PROCEDURES

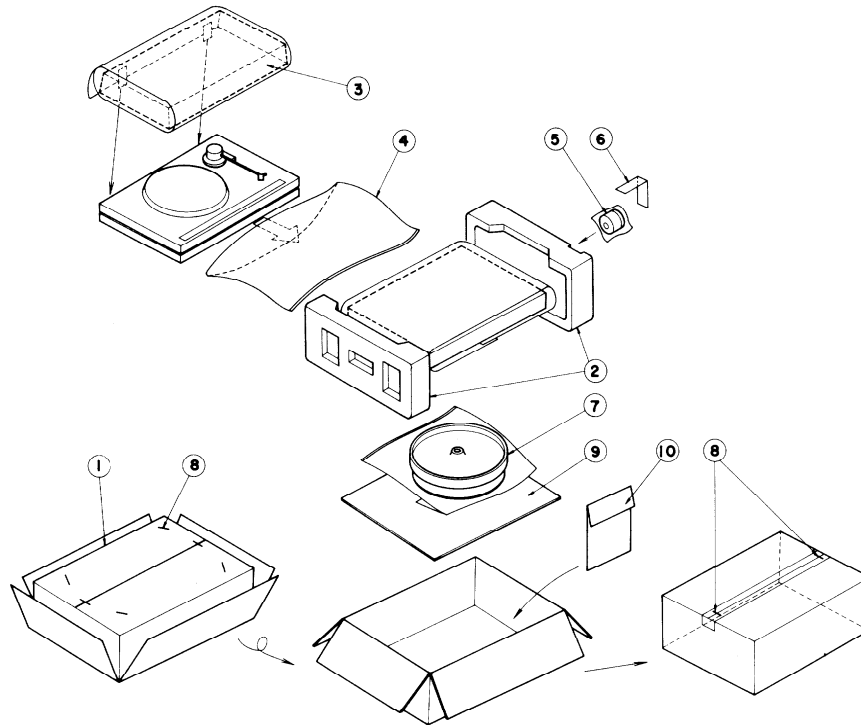

REF. NO.	PARTS NO.	DESCRIPTION
1	29050460	Master carton box
2	29090568	Pad
3	29100050	Protection bag
4	29100049	460x620mm, Poly bag
5	29100002	80x150mm, Poly bag
	24501385	Counter weight
6	260013	Tape
7	29100046	370x470mm, Poly bag
	24509111-1	T.T mat
	24502120	Turntable platter
8	282301	Sealing hook
9	29090566	Pad sheet
10		Accessory bag ass'y
	29340519	Instruction manual (D)
	29340520	Instruction manual (G/Q/U)
	24509197	Overhang gauge
	292049A	45 r.p.m. adaptor
	29365006	Warranty card (N)
	29365005-3	Warranty card (V)
	29358002	Service station list (N)
	24501330	Cartridge mounting parts ass'y (D)
	25055018	CV-K-1, Conversion plug
11	260012	Damptron tape

Note:

(N): Only U.S.A. model
 (U): Only West Germany model
 (G): Only 220V model
 (D): Only 120V model
 (Q): Only 240V model
 (U): Only Universal model

ONKYO CORPORATION

International Division: No. 24 Mori Bldg., 23-5, 3-chome, Nishi-Shinbashi, Minato-ku, Tokyo, Japan
 Telex: 2423551 ONKYO J. Phone: 03-432-6981

ONKYO U.S.A. CORPORATION
Eastern Office

42-07 20th Avenue, Long Island City, New York 11105, U.S.A. Phone: (212) 728-4639

Midwest Office

935 Sivert Drive, Wooddale, Illinois 60191, U.S.A. Phone: (312) 595-2970

C/O Damark Industries, Inc.

20520 Nordhoff Chatsworth, Cal. 91311, U.S.A. Phone: (213) 998-6501

ONKYO DEUTSCHLAND GMBH, ELECTRONICS

8034 München-Germering, Industriestrasse 18, West Germany. Telex: 521726 Telefon: (089)-84-3071